

LR CLEANROOM GRID SYSTEMS

GORDON
CLEANROOM PRODUCTS DIVISION

LIGHT-DUTY, GASKETED, WIRE-SUSPENDED CEILINGS



LR CLEANROOM GRID SYSTEMS

Gordon Cleanroom products LR-15 ceiling system is designed primarily for use in pharmaceutical, hospital and food service cleanroom applications. Extruded aluminum grid members have a ¼" upturned flange to provide a cleanable edge that also conceals the gasket. Blank panels, filters or other ceiling components first contact the gasket to create an airtight seal prior to settling on the tee flange. Grid components are fabricated of extruded aluminum for maximum structural integrity and corrosion resistance, even in harsh environments. Aluminum assembly clips simplify installation and require no special tools to attach grid components. Optional hold-down clips are available to secure blank panels in the grid.

TECHNICAL INFORMATION

EXTRUDED GRID COMPONENTS

- 6063 T-5 aluminum alloy

FINISHES

- Clear satin anodized for harsh environments
- White, water-based acrylic "wet coat" paint finish

FACTORY-APPLIED GASKETS

- Closed-cell PVC, 8# density
- U.S.D.A. approved
- Fungus-resistant (Method 508.1 Mil Std 810-C)
- Flame-resistant (FMYSS #302; burn rate 4" per minute)
- Color: Light grey
- Contact factory for custom gasket availability

GRID LAYOUT MODULES

- 2' x 4'
- 2' x 2'
- Metric or custom module sizes can be provided

LR APPLICATION GUIDELINES

Appropriate for cleanrooms designed to:

- ISO-7 (Class 10,000) or higher
- Use ducted terminal filter modules
- Use cleanroom standard size filters and light fixtures

SUSPENSION AND LOAD DATA

- Minimum 12 gauge hanger wire (furnished by others)
- Hanger Wire Spacing:
 - 4' o.c. for panels up to 5 lbs. per square foot
 - At all 4 corners of filter module and light fixture locations
- Load test recommendations: See Table
- **NOTE: Gordon does not recommend wire-suspended grid systems for use with fan-powered filter modules (FFU's). Consider Gordon rod-suspended grid systems for FFU applications.**



LR PARTS

PART NUMBER	DESCRIPTION	A- WEB DEPTH	B- EXPOSED GASKETED FLANGE	PART LENGTH	PIECES PER CARTON	LINEAL FEET PER CARTON	LBS PER CARTON	WEIGHT PER LINEAR FOOT/W GASKET
LR-15								
LR-15-MT4	Main Tee, Notched 48" o.c.	1-1/2"	1-1/2"	12'	16	192	55	0.31
LR-15-MT2	Main Tee, Notched 24" o.c.	1-1/2"	1-1/2"	12'	16	192	55	0.31
LR-15-48CN	4' Cross Tee, Notched 24" o.c.	1-1/2"	1-1/2"	4'	48	192	54	0.31
LR-15-48NN	4' Cross Tee, No Notch	1-1/2"	1-1/2"	4'	48	192	54	0.31
LR-15-24	2' Cross Tee	1-1/2"	1-1/2"	2'	48	96	27	0.31
WALL ANGLES								
LR-WA-48	Wall Angle, Notched 48" o.c.	1-1/2"	3/4"	12'	24	288	54	0.23
LR-WA-24	Wall Angle, Notched 24" o.c.	1-1/2"	3/4"	12'	24	288	54	0.23
CLIPS								
MTS	Main Tee Splice Clip				One Per Main Tee		0.02	
LR-2 WAY	2-Way Clip				One Per LG Cross Tee		0.01	
LR-1 WAY	1-Way Clip				As Required		0.01	
LRHC	Panel Hold-down Clip				As Required		0.01	
LRHGR	LR Hanger Clip				As Required		0.01	

LR COMPONENTS & ACCESSORIES

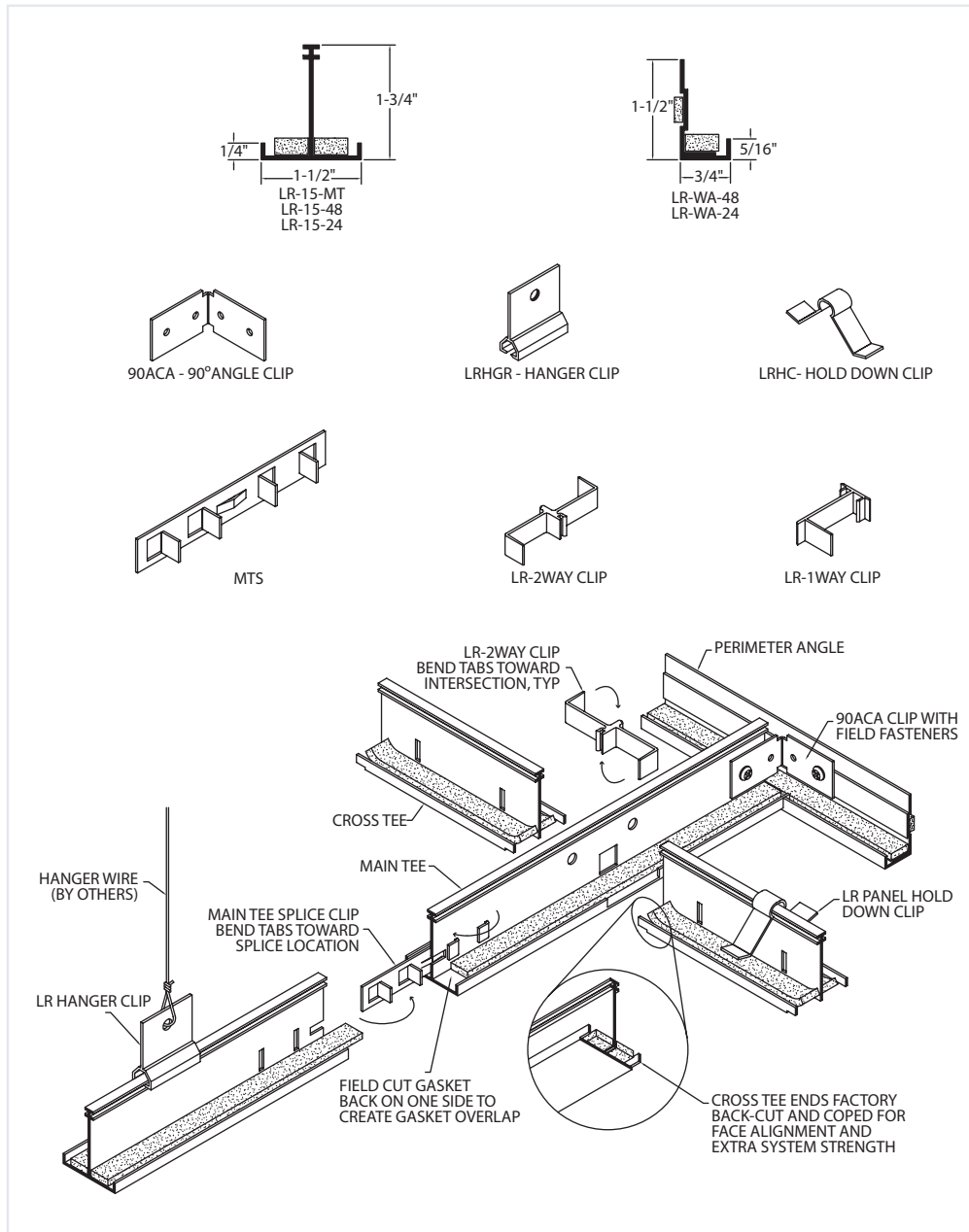

LR LOAD DATA

Load test recommendations outlined in the table at right should not be exceeded, nor should the components be deflected more than 1/360th of their span.

A minimum 12 gauge hanger wire should support all four corners of the filter unit or light fixture.

SYSTEM TYPE	WEB HEIGHT	SPAN HANGER WIRE SPACING	SPACING OF MAIN TEES	APPLIED LOAD LBS./ SQ.FT.
LR-15	1-3/4"	48"	24" 48"	8.9 4.4

GREEN BY DESIGN

- LEED®¹ credits available
- 66% recycled aluminum
 - 33% pre-consumer content
 - 33% post consumer content
- Finishes
 - No phosphate / biodegradable pre-treatment
 - No hazardous waste
 - No VOC's
 - No heavy metals

¹ LEED® is a registered trademark of the U.S. Green Building Council.

Also From **GORDON:**

GORDON
CLEANROOM PRODUCTS DIVISION

5023 HAZEL JONES ROAD, BOSSIER CITY, LA 71111

888.315.1561

800.877.8746 FAX

SALES@GORDONCLEANROOM.COM

GORDONCLEANROOM.COM

